

规格承认

SPECIFICATION FOR APPROVAL

客户名称 Customer	D290		
客户料号 CUSTOMER NO			
产品类别 Product Type	电源适配器 Switch Power Adaptor		
设计编号 Designed No.	9.11.122019101602	产品型号 Model No.	GQ12-120100-HG
样单编号 SAMPLE NO.	191016002	版本 Version	A/0
送样日期 Sample Date	2019-10-18		

客户承认签核 CUSTOMER AUTHORIZED SIGNATURE		

- 1 SPECIFICATION CHANGE RECORD 变更记录..... 3
- 2 DESCRIPTION 概述
 - 2.1 Power Supply Description 产品概述..... 4
 - 2.2 Power Supply Change Notification 变更事前通知..... 4
 - 2.3 Power Supply Frame 电源结构型式..... 4
- 3 ELECTRICAL CHARACTERISTICS 电气性能
 - 3.1 AC Input Voltage and Frequency 输入电压及频率..... 4
 - 3.2 Maximum AC Current 最大输入电流..... 4
 - 3.3 Input Inrush Current 最大浪涌(突入)电流..... 4
 - 3.4 No-load Loss Power 空载功耗..... 4
 - 3.5 Output Voltage 输出电压..... 4
 - 3.6 Output Ripple Voltage 输出纹波电压..... 5
 - 3.7 Time Sequence 时间控制..... 5
 - 3.8 Capacitive load testing 容性负载测试..... 5
 - 3.9 Output Overshoot 输出过冲..... 6
 - 3.10 Output transient response 输出瞬态响应..... 6
 - 3.11 Protection Function 保护功能..... 6
 - 3.12 Average Efficiency 平均效率..... 6
- 4 ENVIRONMENTAL REQUIREMENTS 环境要求
 - 4.1 Temperature 温度..... 7
 - 4.2 Relative Humidity 相对湿度..... 7
 - 4.3 The Sea Level Altitude 海拔高度..... 7
- 5 Reliability 可靠性
 - 5.1 MTBF 平均故障间隔时间..... 7
 - 5.2 Insulation Resistance 绝缘阻抗..... 8
 - 5.3 Hi-Pot 绝缘耐压..... 8
 - 5.4 Leakage Current 漏电流..... 8
 - 5.5 Low Temperature Storage 低温存储..... 8
 - 5.6 High Temperature Storage 高温存储..... 8

5.7 Low Temperature Operating 低温操作..... 9

5.8 High Temperature Operating 高温操作..... 9

5.9 High & Lower Temperature Alternating 高低温交替..... 9

6 SAFETY STANDARD 安全标准

6.1 Safety Standard 安规标准..... 9

6.2 Electromagnetic Compatibility (EMC) 电磁兼容性

6.2.1 EMI 电磁干扰 9

6.2.2 EMS 电磁抗扰 10

7 MECHANICAL CHARACTERISTICS 机械性能

7.1 Bending Test 摇摆(弯曲)测试..... 10

7.2 Tensile Strength Test 拉力测试..... 10

7.3 Drop Test 跌落测试 11

7.4 Vibration test specifications non-operating with packing 振动测试..... 11

7.5 Salt spray test 盐雾测试..... 11

7.6 Input and Output Connections 输入输出连接定义..... 12

7.7 Unit Weight 产品单重..... 12

7.8 Dimension 物理尺寸..... 12

8 APPENDIX DRAWING 附图

8.1 CIRCUIT DIAGRAM 电路图..... 13

8.2 PRINT CIRCUIT BOARD LAYOUT 电路板布局图..... 14

8.3 Overall Drawing 外观图..... 15

8.4 Nameplate Drawing 铭牌图..... 16

8.5 Packing Drawing 包装图..... 17

9 SAMPLE TEST REPORT 样品测试报告

9.1 Sample test 样品测试..... 18

10 IMPORTANT NOTICE 重要提醒..... 19

SPECIFICATION CHANGE RECORD 变更记录

Revision 版本	Change record 变更记录	Arbiter 确认者	Changed date 变更日期
A/0	Primary Release.	江玉英	

APPROVE BY	CHECK BY	PREPARED BY

2.1 Power Supply Description 产品概述

This is a series of general purpose AC/DC adapters which convert 100Vac ~240Vac to a stabilized DC voltage of [12V](#) with rated output current of [1.0A](#).

本通用型电源是将100Vac ~240Vac 交流输入电压转换成稳定的直流电压[12VDC](#)，额定输出电流[1.0A](#)。

2.2 Power Supply Change Notification 变更事前通知

The vendor shall notify customer of significant design changes, prior to implementation. However, process improvements can be an exception.

有重大设计变动时,在变更实施之前,供应商将通知到客户,工艺改善可以例外。

2.3 Power Supply Frame 电源结构型式

- Wall mount 插墙式
 Desk-top 桌上式
 Open frame 开放式结构/裸板
 Other 其它

3 ELECTRICAL CHARACTERISTICS 电气性能

3.1 AC Input Voltage and Frequency 输入电压及频率

2.1.1 Rated Input Voltage 额定输入电压 : [AC100-240V](#)

2.1.2 Reliable Input Voltage 可输入电压范围 : [AC90-264V](#)

2.1.3 Rated Input Frequency 额定输入频率: [50/60Hz](#)

2.1.4 Reliable Input Frequency 可输入频率范围 : [47-63Hz](#)

3.2 Maximum AC Current 最大输入电流

Input rated voltage, Output rated load. Input AC Current [0.4Amps](#) Maximum.

输入额定电压,输出额定负载条件下,最大输入电流为:[0.4Amps](#)。

3.3 Input Inrush Current 最大浪涌(突入)电流

Input [100VAC](#) 60Hz, Output rated load (cold start) inrush Current [40Amps](#) peak.

输入[100Vac](#) 60Hz,输出额定负载(冷启动)条件下,最大浪涌(突入)电流为:[40Amps](#)。

Input [240VAC](#) 50Hz, Output rated load (cold start) inrush Current [50Amps](#) peak.

输入[240Vac](#) 50Hz,输出额定负载(冷启动)条件下,最大浪涌(突入)电流为:[50Amps](#)。

3.4 No-load Loss Power 空载功耗

Input [115/230Vac](#), Output no load. Maximum loss power [0.3Watts](#).

输入[115/230Vac](#)输出空载,最大空载功耗为:[0.3瓦](#)。

3.5 Output Voltage 输出电压

负载 (Load)	最小负载 (Min. Load)	最大负载 (Max. Load)
电流(Current)	0A	1.0A
电压(Voltage)	12Vdc±5%	12Vdc±5%

3.6 Output Ripple Voltage 输出纹波电压

3.6.1 在额定输入及输出的条件下 (25°C) 测试输出纹波电压.

3.6.2 Peak to peak ripple is measured with an oscilloscope with a bandwidth of 20MHz.
纹波量测时示波器选用20MHz带宽限制.

3.6.3 Measurement of ripple should include a 0.1uF ceramic capacitor and a 10uF electrolytic capacitor at the input of the measuring oscilloscope.
测试时在输出端要并联一颗0.1uF的陶瓷电容和一颗10uF的电解电容.

Input	Output Rated Voltage	Output Current	Output Ripple & Noise
120Vac-240Vac	+12V	1.0A	200mVp-p Max.

3.7 Time Sequence 时序特性

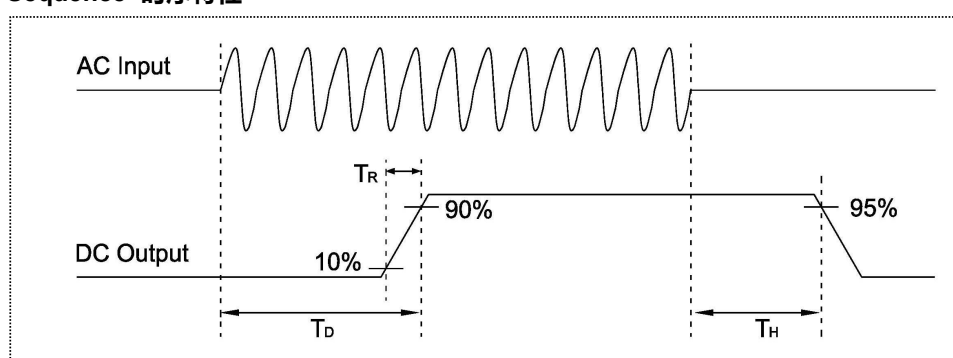

3.7.1 Turn-On Delay Time(T_D) 开机输出延迟时间:

The maximum cold start turn-on delay shall not exceed **3** second at input 100-240Vac and the rated load condition.

在输入100-240Vac,额定负载情况下,最大冷启动打开的延迟不会超出**3**秒.

3.7.2 Hold-Up Time(T_H) 关机输出维持时间:

3.7.2.1 The maximum turn-off hold-up time shall be least **5mS** at input 100Vac and the rated load condition.

在输入**100Vac**及额定负载情况下,关机输出维持时间不低于**5mS**.

The maximum turn-off hold-up time shall be least **10mS** at input 240Vac and the rated load condition.

在输入**240Vac**及额定负载情况下,关机输出维持时间不低于**10mS**.

3.7.3 Output Rise Time(T_R) 输出上升时间:

Input 100Vac/240Vac and rated load, The rise time shall not exceed **100mS** that the output voltage rise from **10%** to **90%** rated voltage.

在输入100Vac/240Vac,输出额定负载条件下,输出电压由**10%**额定电压上升至**90%**额定电压的上升时间不会超过**100mS**.

3.8 Capacitive load testing 容性负载测试

The output is connected to 0-100uF capacitor with different load output at startup output monotonically rise.

输出接0-100uF的电容带不同载输出启动时输出单调上升.

3.9 Output Overshoot 输出过冲

3.9.1 [10%](#) Rated Voltage Max. when the power turn on.

当电源开机时,过冲电压值最大为额定电压值的[10%](#).

3.9.2 [10%](#) Rated Voltage Max. when the power turn off.

当电源关机时,过冲电压值最大为额定电压值的[10%](#).

Output Rated Voltage	Overshoot Voltage(V)	
	Turn on	Turn off
+12V	10%	10%

3.10 Output transient response 输出瞬态响应

Output Voltage Tolerance Limited 输出电压范围	Rate Slew 斜率	Load change 负载变化
12Vdc±10%	0.25A/μs	20% to 80% Load

Transient response measurements shall be made with a load changing repetition rate of 100Hz to 10kHz.

测量瞬态响应与负载改变的频率应在 100Hz至10kHz。

3.11 Protection Function 保护功能

3.11.1 Over Voltage Protection 过压保护

The power supply shall protect itself from any over voltage condition.

电源在过压情况下可自动保护。

3.11.2 Over Current Protection 过流保护

The power supply shall protect itself from any over current condition.

it can be automatically restored to be normal when the overcurrent condition removed, the Overcurrent output current is between [1.1-2](#)times .

电源在过流情况下可自动保护,当过流情况解除后,可自动恢复正常。过流保护在输出电流的[1.1-2](#)倍之间.

3.11.3 Short Circuit Protection 短路保护

Shorting of output will not cause power supply to damage, or any safety hazard.

The power supply shall resume normal operation after the short is removed.

输出短路时电源不会损坏,不会有任何的安全危险,短路解除后电源恢复正常工作。

3.11.4 Input Protection 输入保护

The power supply has a current fuse to protect itself.

该电源由一颗电流保险丝来达到输入保护。

3.12 Average Efficiency 平均效率

Input [115/230Vac](#). and 100%,75%,50%,25% Rated Load condition. Average efficiency (η):[77.75%](#) Min(Level [V](#)).

在输入[115/230Vac](#),输出100%,75%,50%,25%额定负载,平均效率 (η): [77.75%](#) Min([V](#)级).

4.1 Temperature 温度

4.1.1 Storage temperature (Non-operating) 可存储温度(非操作状态):

-10 to 70 degrees C [-10] 至 [70]摄氏度.

Typical values:25 degrees C. 典型值:25摄氏度.

4.1.2 Operating temperature Limits 可操作温度:

0 to 40 degrees C. [0] 至 [40]摄氏度.

Typical values:25 degrees C. 典型值:25摄氏度.

4.2 Relative Humidity 相对湿度

4.2.1 Storage Humidity (Non-operating) 存储湿度(非操作状态):

5% to 90% RH (Non-condensing) [5%] 至 [90%],无凝水状态.

4.2.2 Operating Humidity Limits 操作湿度:

5% to 90% RH (Non-condensing) [5%] 至 [90%],无凝水状态.

4.3 The Sea Level Altitude 海拔高度

4.3.1 Storage Altitude 可存储海拔度(非操作状态):

0 to +5,000m above the sea level [0] 至 [5,000]米.

4.3.2 Operating Altitude 可工作海拔度:

0 to +2,000m above the sea level [0] 至 [2,000]米.

4.4 Cooling Method 冷却方法

Natural convection or Forced air 自然冷却或通风冷却

5 Reliability 可靠性

5.1 MTBF: Mean Time Between Failure 平均故障间隔时间

The power supply shall be designed and manufactured to have more than 20,000 operating hours (about 2.28 years for 24-hour-operation a day) of mean time between failure (MTBF) at 90% of confidence level while operating under the prevailing conditions below.

在如下条件,该电源设计和制造平均故障间隔时间(MTBF)将超过20,000个操作时间(大约操作24小时/每天/2.28年),信心指数为90%。

AC Input Voltage:	115/230Vac
输入电压:	115/230Vac
Output Load:	of Rated load
输出负载:	额定负载条件
Ambient Temperature:	at <u>25</u> degrees C Room Temperature
环境温度:	室温 <u>25</u> 摄氏度

5.2 Insulation Resistance 绝缘阻抗

Test Points	检测部位	Condition & Specification 条件及规格
Input to Output	输入-输出	DC500V 100MΩ min. (at ambient temperature 25 degree C, humidity 90%) DC500V 100MΩ 最小. (在室温25摄氏度,湿度90%条件下).
Input to Case	输入- 外壳	DC500V 100MΩ min. (at ambient temperature 25 degree C, humidity 90%) DC500V 100MΩ 最小. (在室温25摄氏度,湿度90%条件下).
Output To Case	输出 - 外壳	Non Isolated

5.3 Hi-Pot 绝缘耐压

Test Points	检测部位	Condition & Specification 条件及规格
Input to Output	输入-输出	3000Vac 50Hz, 60S, ≤10mA.
Input to Case	输入- 外壳	3000Vac 50Hz, 60S, ≤10mA.

When AC voltage of [3KV](#) is applied, and the voltage applied to the insulation under test is gradually raised from zero to the prescribed voltage in [2s](#), and held at that value for 60s between the input and output and between the input and housing, the current sensitivity shall be less than [10mA](#). After this test, the adapter shall exhibit no electrical and mechanical abnormalities. (AC voltage of [3.75KV, 2s](#) and sensitivity current [10mA](#) shall be applied to the product line).

在输入端对输出端及输入端对外壳间施加了[3KV](#)电压,并且测试中施加在绝缘上的电压是在[2s](#)内由0V逐渐上升到规定值,然后保持[60S](#),电流灵敏度设置在[10mA](#)。经过以上测试,电源应不发生电气及机械上的异常。(注:在生产线批量生产时以[3.75KV, 2s 10mA](#)进行测试)。

5.4 Leakage Current 漏电流

The leakage current shall not exceed [0.25mA](#) for [Class II](#) when power supply is operated maximum input voltage and maximum load.

当电源供应器操作在最大输入电压及最大负载情况下,其漏电流应小于[0.25mA](#),满足[Class II](#)等级。

5.5 Low Temperature Storage 低温存储

Keep the parts unpacked without connecting to the power for [96](#) hours at [-10°C](#). Electrical character tested and appearance after resuming [1](#) hours at room temperature. The electrical performance and appearance should be normal.

产品不包装,不通电。在[-10°C](#)条件下保存[96](#)小时,常温恢复[1](#)小时后,进行外观、电气性能检测。产品电气性能及外观应是正常的。

5.6 High Temperature Storage 高温存储

Keep the parts unpacked without connecting to the power for [96](#) hours at [70°C](#). Electrical character tested and appearance after resuming [1](#) hours at room temperature. The electrical performance and appearance should be normal.

产品不包装,不通电。在[70°C](#)条件下保存[96](#)小时,常温恢复[1](#)小时后,进行外观、电气性能检测。产品电气性能及外观应是正常的。

5.7 Low Temperature Operating 低温操作

Keep the parts unpacked without connecting to the power, Adjust the temperature of the incubator by the speed of 1 ° C / min. to 0 ° C for 48 hours, 3 times a power-on test, and then continued to maintain the power-on State, to the end of the experiment; test time about 48 hours (load about 46 hours), check the electrical function after resuming 2 hours at room temperature; The electrical performance should be normal.

将样品放到温箱中,产品不包装,不通电,按1°C/min的速度调节温箱温度至0°C,保持48小时后,进行3次上电测试,然后持续保持上电工作状态,至实验结束; 实验时间共48小时(带载约46小时),试验结束后,常温恢复2个小时,检查电气功能. 产品电气性能及外观应是正常的.

5.8 High Temperature Operating 高温操作

Keep the parts unpacked without connecting to the power, Adjust the temperature of the incubator by the speed of 1 ° C / min. to 40 ° C for 48 hours, 3 times a power-on test, and then continued to maintain the power-on State, to the end of the experiment; test time about 48 hours (load about 46 hours), check the electrical function after resuming 2 hours at room temperature; The electrical performance should be normal.

将样品放到温箱中,产品不包装,不通电,按1°C/min的速度调节温箱温度至40°C,保持48小时后,进行3次上电测试,然后持续保持上电工作状态,至实验结束; 实验时间共48小时(带载约46小时),试验结束后,常温恢复2个小时,检查电气功能. 产品电气性能应是正常的.

5.9 High & Lower Temperature Cycle 高低温循环

Sample connecting to the power incubator humidity rose to 90% within 1 hour, the temperature maintained at 0°C; Within three hours the temperature rose to 40 ° C, humidity 90%, to maintain 9 hours; Then drop the temperature within 3 hours to 0 ° C, humidity 90% to maintain 9 hours; The above is a cycle, a total of two cycles. The indicators & functions shall be normal in the testing process and the end of the test.

样品通电,温箱湿度在1小时内升到90%,温度保持在0°C;再将温度在3小时内上升到40°C,湿度在90%,保持9小时;将温度在3小时内下降到0°C,湿度在90%,保持9小时; 以上为一个循环,共进行2个循环. 产品在测试过程中以及测试结束后,要求指标、功能全部正常.

6 SAFETY STANDARD 安全标准

6.1 SAFETY STANDARD 安全标准

* Meet

6.2 ELECTROMAGNETIC COMPATIBILITY (EMC) 电磁兼容性

6.2.1 EMI 电磁干扰

This power supply shall compliance with the following Criterion 本电源将遵照以下标准:

6.2.1.1 Conduction Emission 传导干扰度

6.2.1.2 Radiated Emission 辐射干扰度

This power supply shall compliance with the following Criterion 本电源将遵照以下标准:

6.2.2.1 ESD 静电抗扰度

Standard: * [GB/T 17626.2](#)

AIR DISCHARGE at [8KV](#), CONTACT DISCHARGE at [4KV](#).

6.2.2.2 EFT 脉冲群抗扰度

Standard: * [GB/T17626.4](#) [±1KV](#)

6.2.2.3 Surge 雷击浪涌

differential mode: [1KV](#)

common mode: [1KV](#)

The common mode must test with end application. 共模雷击搭配客户产品测试.

Remark: EMC-SPECIFICATION test with the Pure resistance as load to test, and we only responsible for the product we supplied.

电磁兼容性测试是以纯电阻作为负载测试的，我们只对单品测试负责。

7 MECHANICAL CHARACTERISTICS 机械性能

7.1 Bending Test 摇摆(弯曲)测试

Test the metallurgical equipment with fixed plug, handing weight is [300g](#), [±60](#) degrees from side to side, swing [45](#) times per minute, swing more than [1000](#) times (Remark: +/-6- degrees, that is to say 120 degrees for a cycle, counting 1 times)

以测试治具固定Plug,吊重[300g](#),左右摇摆[±60](#)度,每分钟摇摆[45](#)次, 摇摆[1000](#)次以上(注:±60度即120度为一个循环,算1次)

7.2 Tensile Strength Test 拉力测试

put the weight of [4 kg](#) on SR for [1](#) minute, SR should not shift or damage.

put the weight of [7 kg](#) on DC Cable after [1](#) minute, inner core shall not break .

在DC线的SR卡上施以[4Kg](#)之重量1分钟, 产品无短路, 无开路, 围卡无松脱。

在DC线线体上施以[7Kg](#)之重量1分钟后, 检查内芯不可有拉断现象。

7.3 Drop Test 跌落测试

The adapter shall exhibit no abnormality in mechanical or electrical performance when it is dropped 6 times to hardwood(20mm thickness) from a height of 1m, with each of the 6 different sides of the adapter 1 times. The electrical and mechanical performance should be normal after the tested. Small nicks or slight deformations in the corners of the housing, or cracks not penetrating the inside may be accepted. (at:25°C±5°C).

适配器经过落地测试后应无机械或电气性能异常,从1m垂直高度自由跌落到20mm厚度的硬木质板上(硬木质板应放置于水泥基座或同等无弹性的地面上),共跌落6次,6个不同面各1次. 测试后产品电气和机械功能正常,外观或角落有轻微的变形或出现不穿透裂纹是可以接受的(在25°C±5°C)。

7.4 Vibration test specifications non-operating with packing 振动测试(未运行,带包装)

10Hz to 55Hz with sweep at a breadth 2.0mm for 20 Minutes for each of the perpendicular axes X,Y,Z. After the test the electrical performance shall be normal.

振动频率: 10Hz-55Hz; 振幅:2mm; X、Y、Z三个方向各20分钟; 振动测试后产品电气性能应是正常的。

7.5 Salt spray test 盐雾测试

The most typical of sample surface exposed, Sample pretreatment at 35 ° C for 2 hours in front of the salt spray test; Concentration of 5% NACL solution, 35 degrees under the conditions of continuous spray 8 hours, and then moved out for 16 hours to dry. The electrical performance should be normal.

将样品最典型的表面暴露在外, 样品在盐雾测试前在35°C进行2小时的预处理; 浓度5% NACL溶液,35度条件下连续喷雾8个小时,然后移出进行16小时晾干, 产品电气性能应是正常的。

7.6.1 Input Connection 输入连接:**7.6.1.1 Wall plug or Cord to Cord Type 插墙式或导线式**

- | | | |
|--|---|------------------------------------|
| <input checked="" type="checkbox"/> For EU | <input type="checkbox"/> For UL 3PIN | <input type="checkbox"/> For CCC |
| <input type="checkbox"/> For PSE | <input type="checkbox"/> For UK 3PIN 两铜一塑 | <input type="checkbox"/> For Korea |
| <input type="checkbox"/> For IRAM | <input type="checkbox"/> For SAA | <input type="checkbox"/> For UL |
| <input type="checkbox"/> For Brazil | <input type="checkbox"/> For PSB | <input type="checkbox"/> Others |

7.6.1.2 Socket and Terminal Type 母座或端子式

- | | | |
|--------------------------------------|--------------------------------------|--|
| <input type="checkbox"/> 2PIN Socket | <input type="checkbox"/> 3PIN Socket | <input type="checkbox"/> Terminal type |
|--------------------------------------|--------------------------------------|--|

7.6.2 Output Connector 输出连接:**7.6.2.1 Output Plug 输出插头**[5.5*2.1*10mm 直头 半绝缘](#)**7.6.2.2 Polarity 极性**[内正外负](#)**7.6.3 Input & Output Cord 输入输出线材:****7.6.3.1 Length and Cord 长度及颜色**[1500+50/-0mm,BLACK](#)**7.6.3.2 Specifition 规格**[UL2468,26AWG/2C](#)**7.7 Unit Weigth 产品单重**The weight of the unit power supply shall be about [73.8](#) g(Ref).产品单重大约: [73.8](#) 克 (供参考).**7.8 Dimension 物理尺寸**[L:60.6*W:29*H:40mm](#)

See appearance figure 详见外观图.

8.2.1 silkscreen Top 顶层丝印

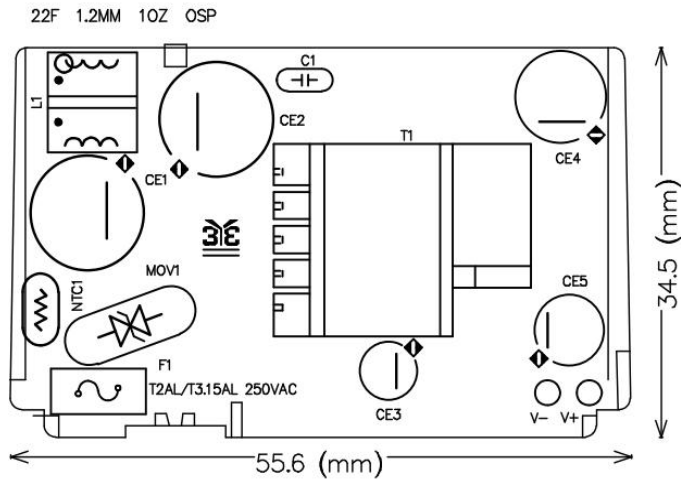

8.2.2 silkscreen bottom 底层丝印

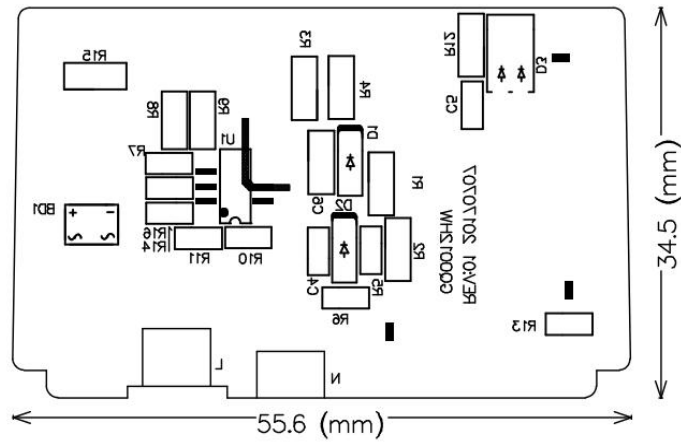

8.2.3 copper foil 铜箔层

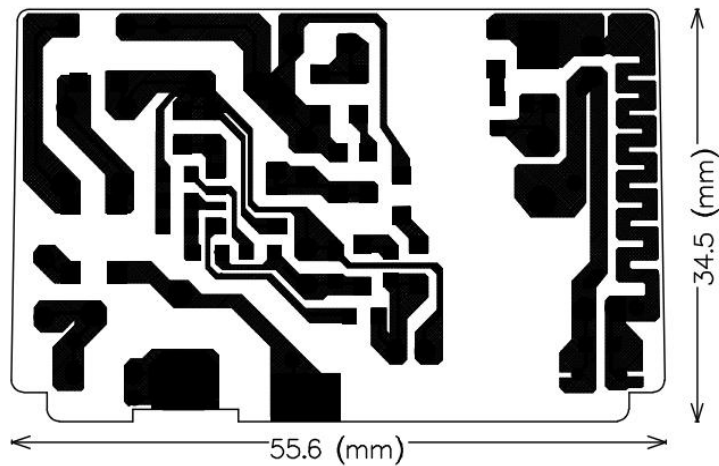

8.3 Overall Drawing 外观图

外壳(Enclosure): BALCK (LEAD FREE) 外壳: 黑色

外壳尺寸(The power supply size): L:60.6*W:29*H:40mm

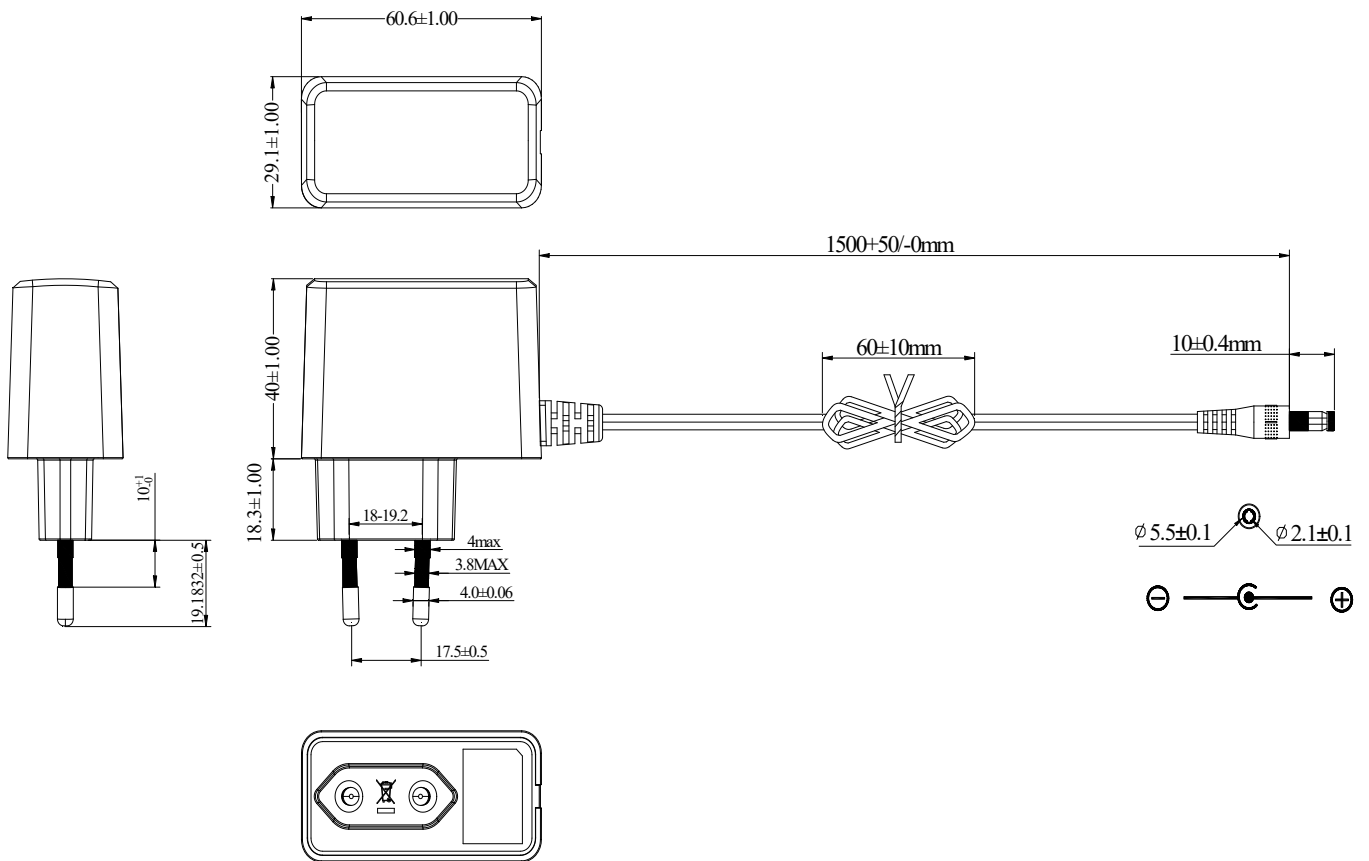

UL2468 26AWG 1.5M 黑色 (BLACK) DC PLUG: $\phi 5.5 \times 2.1 \times 10$ mm/180° (半绝缘) 内正外负 音叉车沟

8.4 Nameplate Drawing 铭牌图

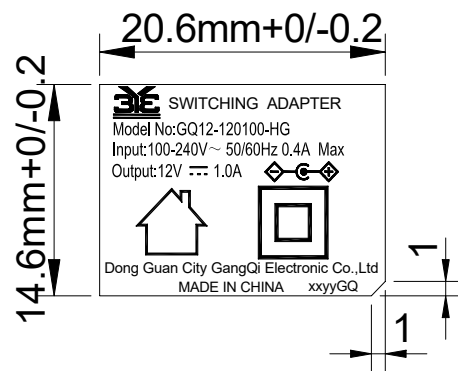
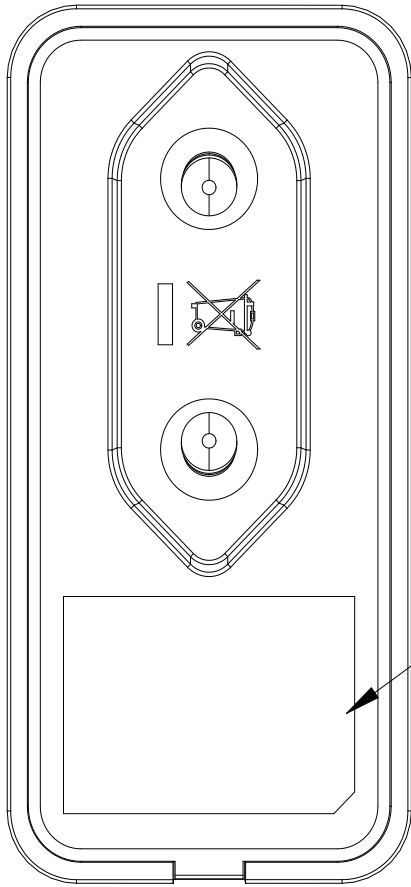

“xx yy”

年 丁 月

具体时间根据实际生产时间定义!

此内容镭雕于外壳
外框不用镭雕

8.5 Packing Drawing 包装图

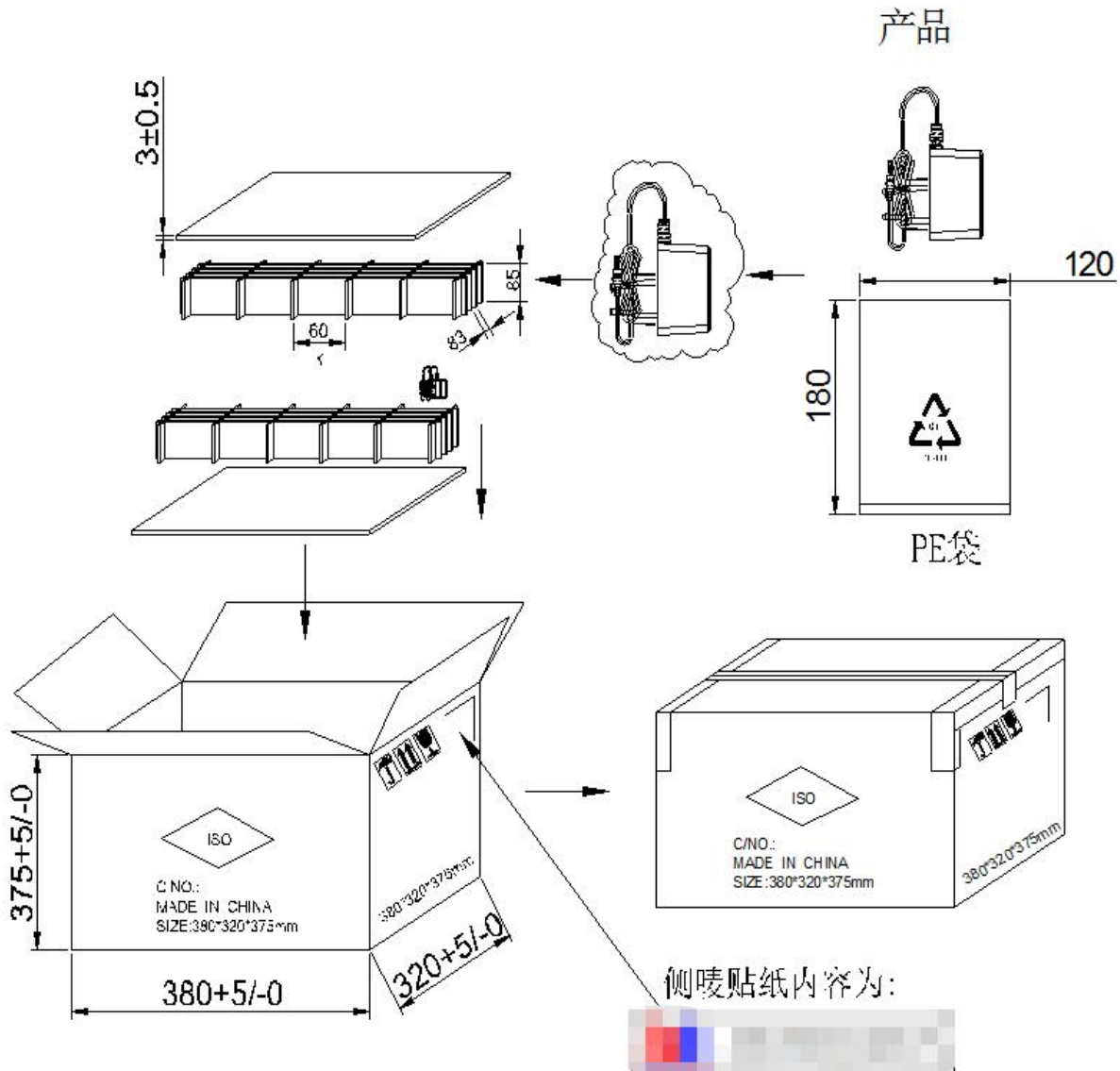

9.1 Sample test 样品测试

样品检验记录表

客户	D290	客户编号		室温	25℃					
产品型号	GQ12-120100-HG	产品编号		日期	2019/10/17					
输入电压/频率	90-264Vac 50-60HZ			输出电压/电流	12V/1.0A					
测试内容		1#样机				2#样机				判定 PASS/NG
测试项目	测试标准	90V	100V	240V	264V	90V	100V	240V	264V	
空载电压(±5%)	11.4-12.6V	11.95	11.95	11.92	11.92	11.96	11.95	11.92	11.92	PASS
空载纹波与噪声	<200mV	25	24	30	32	25	27	32	34	PASS
满载电压(±5%)	11.4-12.6V	11.84	11.86	11.85	11.86	11.85	11.87	11.87	11.87	PASS
满载纹波与噪声	<200mV	146	141	132	128	139	133	123	121	PASS
最大输入电流	0.4A	0.29	0.26	0.15	0.14	0.28	0.26	0.15	0.14	PASS
短路保护	无损坏可恢复 OK/NG	OK	OK	OK	OK	OK	OK	OK	OK	PASS
过流保护	1.1-2A between	1.41	1.42	1.39	1.39	1.36	1.38	1.34	1.36	PASS
恒流测试	CV:	/	/	/	/	/	/	/	/	/
	CV:	/	/	/	/	/	/	/	/	/
绝缘强度测试	3750V /50HZ	泄漏电流		绝缘击穿: <input type="checkbox"/> 有 <input checked="" type="checkbox"/> 无		泄漏电流:		绝缘击穿: <input type="checkbox"/> 有 <input checked="" type="checkbox"/> 无		PASS
绝缘阻抗测试	500V / 30MΩ	绝缘阻抗		绝缘击穿: <input type="checkbox"/> 有 <input checked="" type="checkbox"/> 无		绝缘阻抗:		绝缘击穿: <input type="checkbox"/> 有 <input checked="" type="checkbox"/> 无		PASS
能效测试(1#)	空载功耗:0.3W	输入电压	100%	75%	50%	25%	平均效率	空载输入功耗	PASS	
	平均效率:77.75%	115V	79.82	80.81	81.69	81.52	80.96	0.12	PASS	
		230V	80.63	81.23	81.44	80.16	80.87	0.13	PASS	
能效测试(2#)	空载功耗:0.3W	输入电压	100%	75%	50%	25%	平均效率	空载输入功耗	PASS	
	平均效率:77.75%	115V	80	80.77	81.66	81.74	81.04	0.12	PASS	
		230V	80.77	81.36	81.53	80.59	81.07	0.12	PASS	
90V/264V输入时满载开关机测试	各10次	正常开机: <input checked="" type="checkbox"/> OK <input type="checkbox"/> NG				正常开机: <input checked="" type="checkbox"/> OK <input type="checkbox"/> NG				PASS
样品单号:	191016002					判定结果:	PASS			
基本电性能测试: <input checked="" type="checkbox"/> OK <input type="checkbox"/> NG						EMI测试: <input checked="" type="checkbox"/> OK <input type="checkbox"/> NG				
雷击测试: <input checked="" type="checkbox"/> OK <input type="checkbox"/> NG						温升测试: <input checked="" type="checkbox"/> OK <input type="checkbox"/> NG				
测试: 熊齐艳			品管确认:			核准: 黄洋				
备注:										